

**POLE/BASE**

SEQUOIA LIGHTING SYSTEMS

**PLANT HOLDER**

**DESIGN  
PBN922B**

**NOSTALGIA**

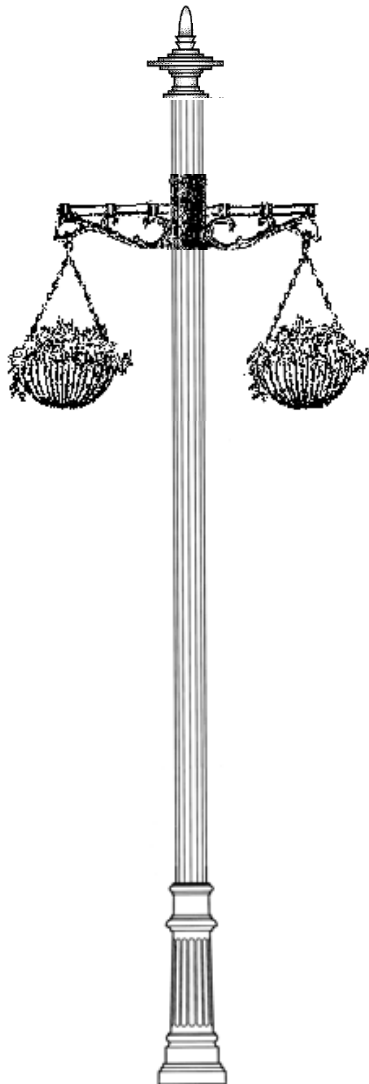

**EAST ON II SERIES**

**POLE BASE DATA**

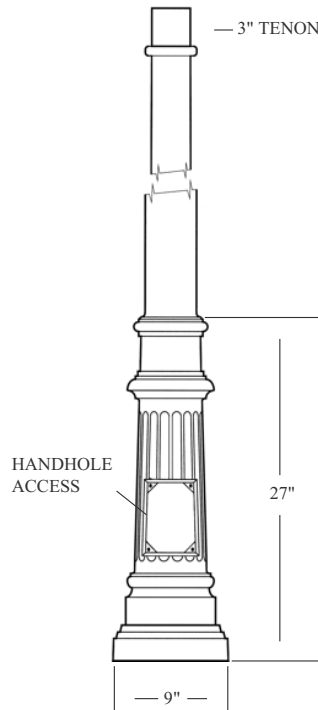

**SHAFT OPTIONS**

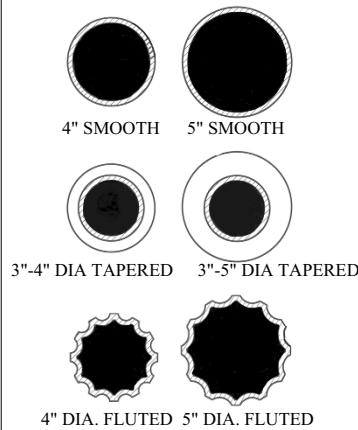

**SPECIFICATIONS**

Lighting standards shall be all aluminum, one piece construction. All aluminum alloys comply with metallurgical and mechanical properties set forth in the Aluminum Association Standards. Each pole is tapered and fluted or smooth upper base design resting on the lower base section.

**SHAFT**

The shaft is extruded from ASTM 6061 aluminum alloy tubing or tapered ASTM 6063. Each pole has a fluted or smooth, tapered or straight upper section on a cast aluminum decorative base. Located in the decorative base of the standard is a large handhole door opening with cover for easy wiring access and fusing.

**ANCHOR BOLTS**

Furnished with each standard are four hot dip galvanized anchor bolts, each with double nuts and double flat washers. Each anchor bolt assembly is provided with a 4" tail. Anchor bolt settings are provided to the customer with each shipment.

**FINISH**

Each lighting standard is cleaned, etched and primed prior to the painting process. Standard colors are black, green, bronze or verde patina. All paint is applied by either powder coat or wet spray process. Custom colors and finishes are also available.

**ORDERING NUMBER LOGIC**

PRODUCT I.D.	SHAFT TYPE	OVERALL HT.	MATERIAL TYPE	COLOR	OPTIONS
PBN906	4" = Dia. Fluted	10 = 10'	AA = Aluminum	BL = Black BR = Bronze VP = Verde Patina GY = Gray UP = Unpainted CC = Custom	PH = Plant Holder

**SEQUOIA LIGHTING**  
CORPORATION

MANUFACTURERS OF QUALITY LIGHTING PRODUCTS

13644 George Blvd, Suite 1, Victorville, CA, 92394 (760) 246-5213 FAX (760) 246-5294 www.sequoialighting.com