

# LUMINAIRE

SEQUOIA LIGHTING SYSTEMS

# PLANT HOLDER

DESIGN  
PBN922

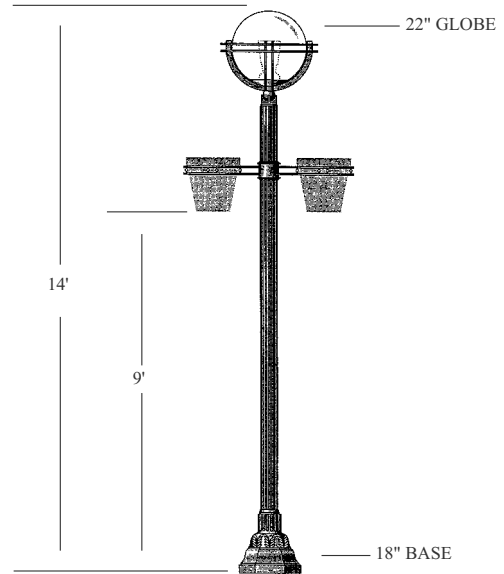
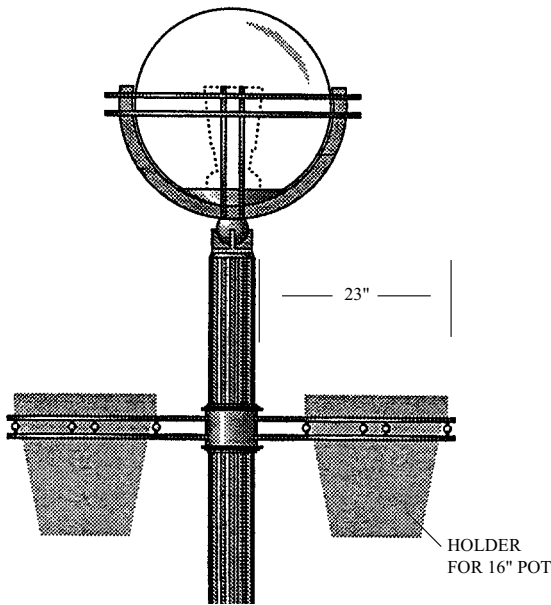

SHOWN ON 14' POLE MOUNTED AT 9'

## SPECIFICATIONS

**Luminaire Name:** Plant Holder  
**Description:** Decorative plant holder that adapts to any type of light standard, available in single and double holder styles

**Material:** Aluminum AA319.OF  
**Globe/Panels:** Acrylic / Polycarbonate UV stabilized / Glass  
**Wattage/Lamping:**

- Mercury Vapor (100, 175 or 250 watt)
- High Pressure Sodium (70, 100, 150, 200 or 250 watt)
- Metal Halide (100, 175, 250 watt)
- QL Induction (55, 85 watt)
- Incandescent

**Distribution:** Symmetric or Asymmetric  
**Voltage:** 120, 208, 240, 277 or 480 volt  
**Options:** House side shield / Photo control / Finial / Activated

Charcoal Filter / Fusing

**Dimensions:** All dimensions are nominal  
**Photometry:** Available upon request on I.E.S. formatted disk  
**Warranty:** Fixture shall be warranted to be free of defects for two years. Ballast components shall carry the ballast manufacturer's limited warranty

## FINISH

Three Stage:

- Cleaned and Etched
- Primered
- Powder coated or wet painted

**Colors:** Black, bronze, green, gray, swedish iron

\* Custom colors available

## APPLICATIONS

- Roadways
- Parking Lots
- Perimeter Ltg.
- Transportation Terminals
- Office Complexes
- School Campus
- Shopping Malls
- Hotels/Motels
- Industrial Sites
- Commercial Developments
- Waterfront Areas
- Parks/Recreational Areas
- Architectural Landscape Ltg.

# SEQUOIA LIGHTING

CORPORATION

MANUFACTURERS OF QUALITY LIGHTING PRODUCTS

13644 George Blvd, Suite 1, Victorville, CA, 92394 (760) 246-5213 FAX (760) 246-5294 www.sequoialighting.com