

POLE/BASE

SEQUOIA LIGHTING SYSTEMS

NOSTALGIA

DESIGN
PBN921B

NOSTALGIA

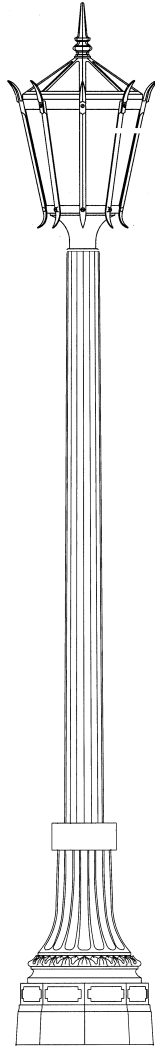

SANT A BARBARA SERIES POLE AND BASE
SHOWN WITH SANTA BARBARA SERIES LUMINAIRE

SPLIT BASE DATA

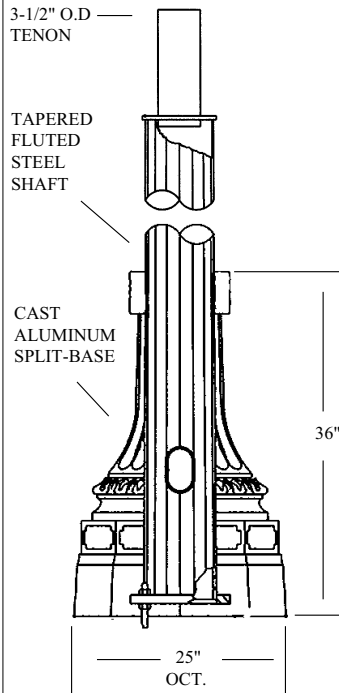

ANCHOR BOLT DETAIL

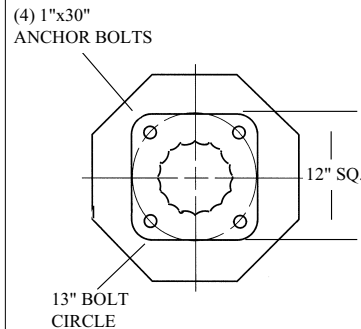

SPECIFICATIONS

Lighting standards shall be all steel with aluminum split base construction. All aluminum alloys shall comply with metallurgical and mechanical properties set forth in the Aluminum Association Standards. Each pole is tapered and fluted or smooth.

SHAFT

The shaft is fabricated steel ASTM A595 and is tapered. Each pole is 16 flute or smooth, tapered or straight with a split type cast aluminum decorative base. Located in the decorative base of the standard is a large hand hole door opening with cover for easy wiring access and fusing.

ANCHOR BOLTS

Furnished with each standard are four hot dipped galvanized anchor bolts, each with double nuts and double flat washers. Each anchor bolt assembly is provided with a 4" tail. Anchor bolt settings are provided to the customer with each shipment.

FINISH

Each lighting standard is cleaned, etched and primed prior to the painting process. Standard colors are black, green, bronze or verde patina. All paint is applied by either powder coat or wet spray process. Custom colors and finishes are also available.

ORDERING NUMBER LOGIC

PRODUCT I.D.	SHAFT TYPE	OVERALL HT.	MATERIAL TYPE	COLOR	OPTIONS
PBN921B	1 = 8" Tapered Fluted	10 = 10' 12 = 12' 14 = 14' 16 = 16' 00 = Custom HT.	AA = Aluminum CS = Steel CC = Custom	BL = Black BR = Bronze VP = Verde Patina GY = Gray UP = Unpainted CC = Custom	OR = Receptacle OB = Banner Arms OF = Flagpole Hldr... OC = Custom Logo OS = Signage OO = None

SEQUOIA LIGHTING
CORPORATION

MANUFACTURERS OF QUALITY LIGHTING PRODUCTS