

**POLE/BASE**

SEQUOIA LIGHTING SYSTEMS

**NOSTALGIA**

DESIGN  
**PBN921**

**NOSTALGIA**

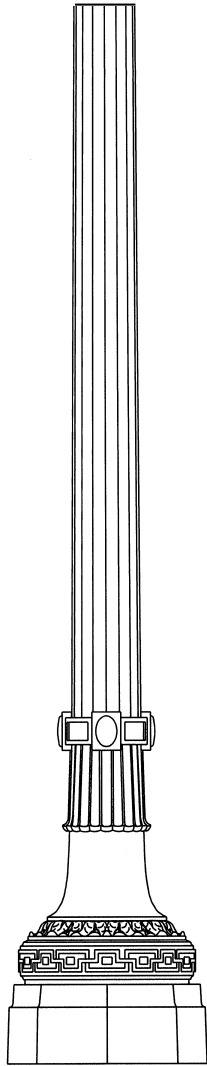

**MULHOLLAND LOS ANGELES SERIES**

**POLE BASE DATA**

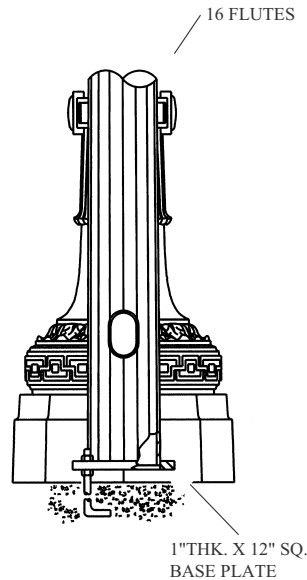

**ANCHOR BOLT DETAIL**

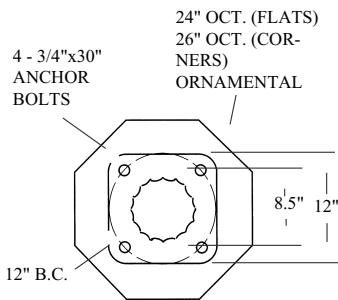

**SPECIFICATIONS**

Lighting standards shall be all steel with aluminum split base construction. All aluminum alloys shall comply with metallurgical and mechanical properties set forth in the Aluminum Association Standards. Each pole is tapered and fluted or smooth.

**SHAFT**

The shaft is fabricated steel ASTM A595 and is tapered. Each pole is 16 flute or smooth, tapered or straight with a split type cast aluminum decorative base. Located in the decorative base of the standard is a large hand hole door opening with cover for easy wiring access and fusing.

**ANCHOR BOLTS**

Furnished with each standard are four hot dip galvanized anchor bolts, each with double nuts and double flat washers. Each anchor bolt assembly is provided with a 4" tail. Anchor bolt settings are provided to the customer with each shipment.

**FINISH**

Each lighting standard is cleaned, etched and primed prior to the painting process. Standard colors are black, green, bronze or verde patina. All paint is applied by either powder coat or wet spray process. Custom colors and finishes are also available.

**ORDERING NUMBER LOGIC**

PRODUCT I.D.	SHAFT TYPE	OVERALL HT.	MATERIAL TYPE	COLOR	OPTIONS
PBN921	<b>3</b> = 3" Dia.. Smooth <b>4</b> = 4" Dia.. Smooth <b>5</b> = 5" Dia.. Smooth <b>6</b> = 4" Dia. Fluted <b>7</b> = 8" Tapered Fluted (LA) <b>8</b> = 3" - 4" Tapered Smooth	<b>08</b> = 8' <b>10</b> = 10' <b>12</b> = 12' <b>14</b> = 14' <b>16</b> = 16' <b>00</b> = Custom HT.	<b>AA</b> = Aluminum <b>CS</b> = Cast Iron <b>CC</b> = Custom	<b>BL</b> = Black <b>BR</b> = Bronze <b>VP</b> = Verde Patina <b>GY</b> = Gray <b>UP</b> = Unpainted <b>CC</b> = Custom	<b>OR</b> = Receptacle <b>OB</b> = Banner Arms <b>OF</b> = Flagpole Hldr. <b>OC</b> = Custom Logo <b>OS</b> = Signage <b>OO</b> = None

**SEQUOIA LIGHTING**  
CORPORATION

MANUFACTURERS OF QUALITY LIGHTING PRODUCTS