

POLE/BASE

SEQUOIA LIGHTING SYSTEMS

NOSTALGIA

DESIGN
PBN917

NOSTALGIA

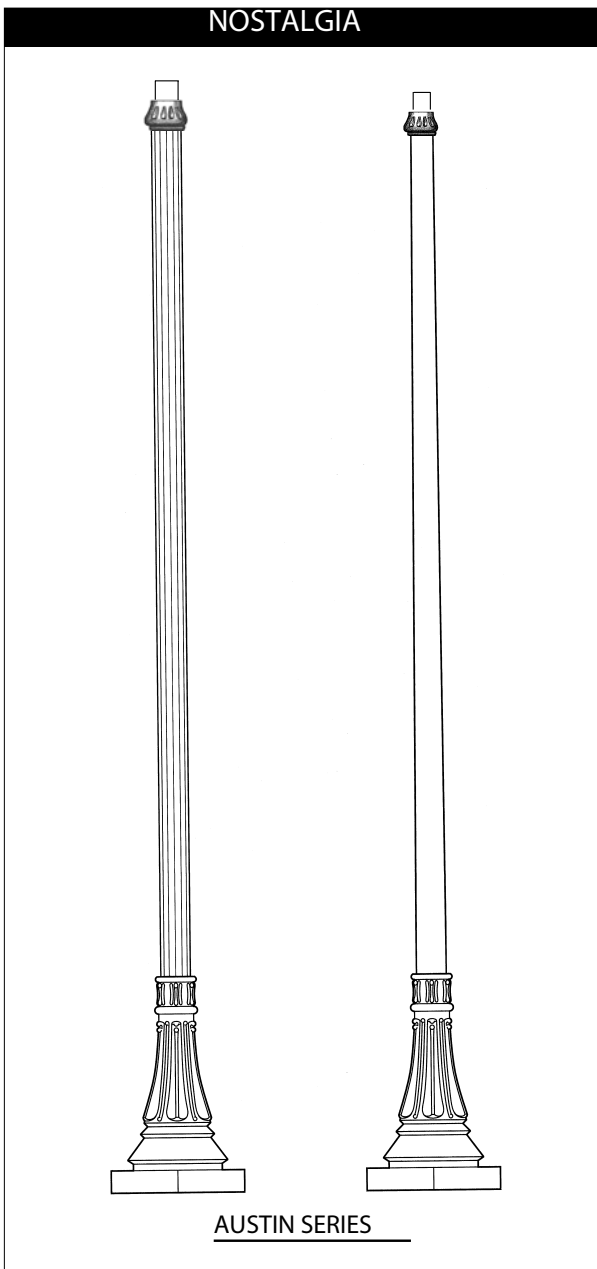

AUSTIN SERIES

POLE BASE DATA

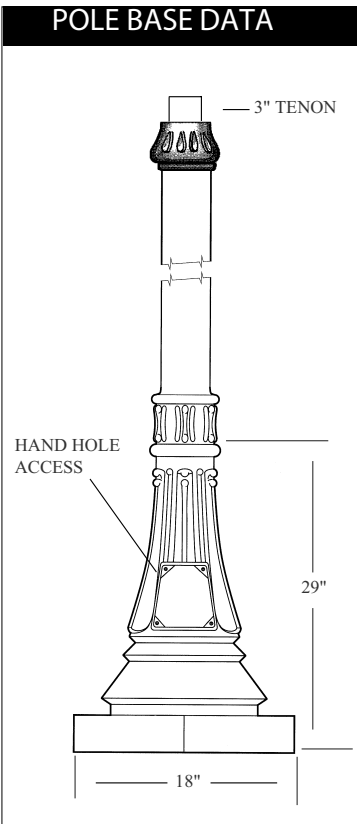

SHAFT OPTIONS

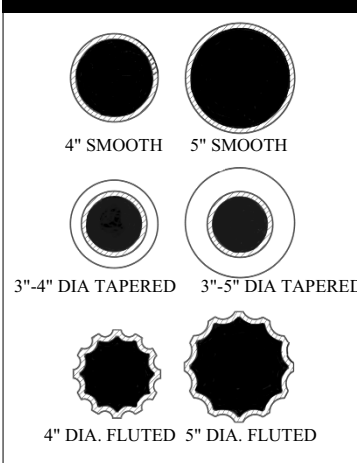

SPECIFICATIONS

Lighting standards shall be all aluminum, one piece construction. All aluminum alloys comply with metallurgical and mechanical properties set forth in the Aluminum Association Standards. Each pole is tapered and fluted or smooth upper base design resting on the lower base section.

SHAFT

The shaft is extruded from ASTM 6061 aluminum alloy tubing or tapered ASTM 6063. Each pole has a fluted or smooth, tapered or straight upper section on a cast aluminum decorative base. Located in the decorative base of the standard is a large hand hole door opening with cover for easy wiring access and fusing.

ANCHOR BOLTS

Furnished with each standard are four hot dip galvanized anchor bolts, each with double nuts and double flat washers. Each anchor bolt assembly is provided with a 4" tail. Anchor bolt settings are provided to the customer with each shipment.

FINISH

Each lighting standard is cleaned, etched and primed prior to the painting process. Standard colors are black, green, bronze or verde patina. All paint is applied by either powder coat or wet spray process. Custom colors and finishes are also available.

ORDERING NUMBER LOGIC

PRODUCT I.D.	SHAFT TYPE	OVERALL HT.	MATERIAL TYPE	COLOR	OPTIONS
PBN917	3 = 3" Dia. Smooth 4 = 4" Dia. Smooth 5 = 4" Dia Fluted 7 = 3"- 4" Tapered Fluted 8 = 3" - 4" Tapered Smooth	08 = 8' 10 = 10' 12 = 12' 00 = Custom HT.	AA = Aluminum CS = Cast Iron CC = Custom	BL = Black BR = Bronze VP = Verde Patina GY = Gray UP = Unpainted CC = Custom	OR = Receptacle OB = Banner Arms OC = Custom Logo OS = Signage AB = Anchor Bolts OO = None

SEQUOIA LIGHTING
CORPORATION

MANUFACTURERS OF QUALITY LIGHTING PRODUCTS