

POLE SIDE MOUNT CLAMP TYPE

LAS 08A

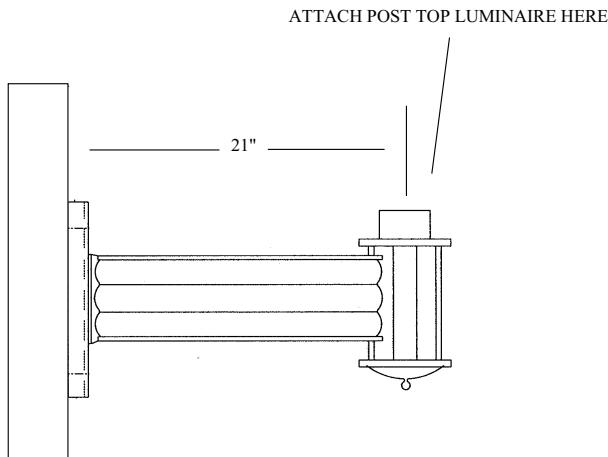

POLE SIDE MOUNT CLAMP TYPE

LAS 08B

SPECIFICATIONS

All Lighting Luminaire arms are constructed from aluminum and are one piece. Each arm is fabricated with a side mounting piece, a bent tube arm, and a decorative type end piece for luminaire mounting. Luminaire arms are welded by a certified welder and can be modified to meet the customer's exact lighting specifications. Post top mounting sections and luminaire mounting sections shall be heavy wall cast aluminum. All aluminum used for casting arms meets ASTM standards. All hardware shall be stainless steel.

FINISH

Finishing process for each luminaire arm configuration consists of a three stage process, first cleaned and etched, then primed and lastly powder coated or wet painted. Standard Colors available are black, bronze, green, gray, verde, white, blue or galvanized. Custom colors are also available upon request.

APPLICATIONS

Luminaire arms are designed to accommodate either round or square poles. Each arm is welded to the pole slip fitter by a certified welder. All welding shall meet ANSI/AWS D.12-90 standards. All luminaire arms are designed for both single and double mounting applications. Custom configurations are also available in the luminaire arm series.

ORDERING LOGIC

For information regarding arms, brackets, number of luminaires required, please see ordering number logic.