

LUMINAIRE

SEQUOIA LIGHTING SYSTEMS

ARMS/PENDANT

DESIGN
LAP08

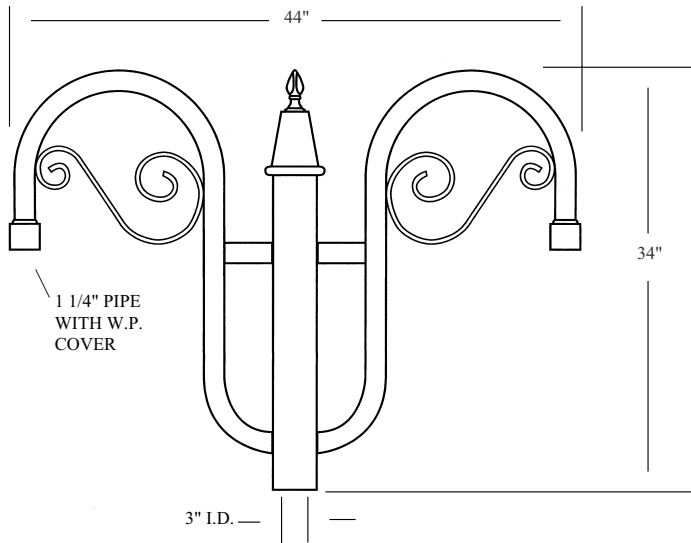

LAP 08A

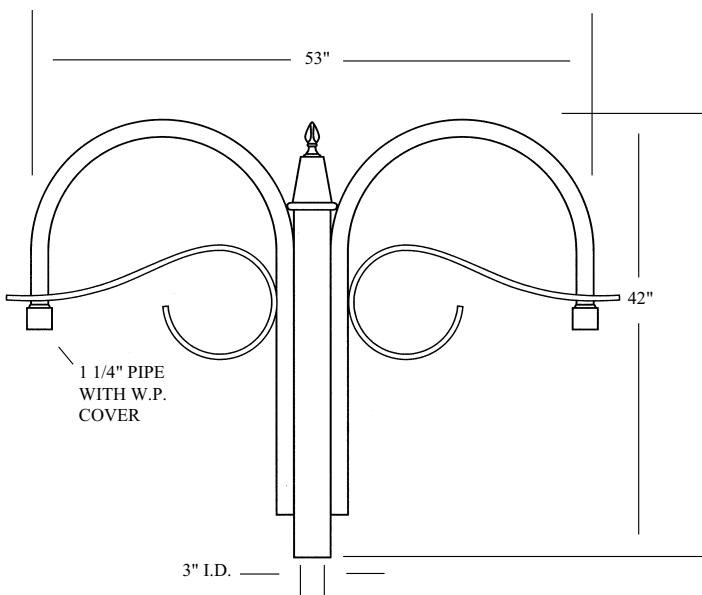

LAP 08B

SPECIFICATIONS

All Aluminum alloys comply with metallurgical and mechanical properties set forth in the Aluminum Association Standards. Sequoia Lighting pole mount brackets and shepherd crooks are constructed out of seamless aluminum tubing. These products include factory installed rubber grommets for wireways, press-on end caps and hub/set screw mounting connections for easy orientation adjustment in the field.

FINISH

Finishing process for each arm configuration consists of a three stage process, first cleaned and etched, then primed and lastly powder coated or wet painted. Standard Colors available are black, bronze, green, gray and verde. Custom colors are also available upon request.

APPLICATIONS

Shepherd's Crook Arms are designed to accommodate either round or square poles. Each arm is welded to the pole slip fitter by a certified welder. All welding shall meet ANSI/AWS D.12-90 standards. Shepherd's Crook Arms are designed for both single and double pendant luminaire mounting applications. Sconce lighting configurations are also available in the Shepherds Crook Arm line.

ORDERING LOGIC

For information regarding arms, brackets, number of luminaires required, please see ordering number logic.

SEQUOIA LIGHTING
CORPORATION

MANUFACTURERS OF QUALITY LIGHTING PRODUCTS

13644 George Blvd, Suite 1, Victorville, CA, 92394 (760) 246-5213 FAX (760) 246-5294 www.sequoialighting.com