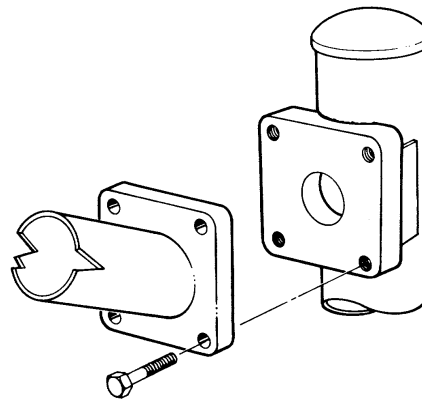
TRIPLEQUAD**SPECIFICATIONS**

All Sequoia Lighting arm flange assemblies are fabricated from heavy duty thick steel and welded to pole for maximum strength. Each has a capacity of one or two luminaire arms depending on mounting configuration. Arm flange assemblies come complete with locking galvanized bolts. Flange arm assemblies are available in three or four set bolt configurations and are hot dip galvanized after fabrication.

FINISH

All flange arm assemblies are cleaned, etched and primed prior to painting. Standard colors are black, bronze, green and verde patina powder coated or wet sprayed to match pole. Custom colors and special finishes along with hot dip galvanizing are also available.

SEQUOIA LIGHTING
CORPORATION

MANUFACTURERS OF QUALITY LIGHTING PRODUCTS