

STEEL SQUARE NON TAPERED

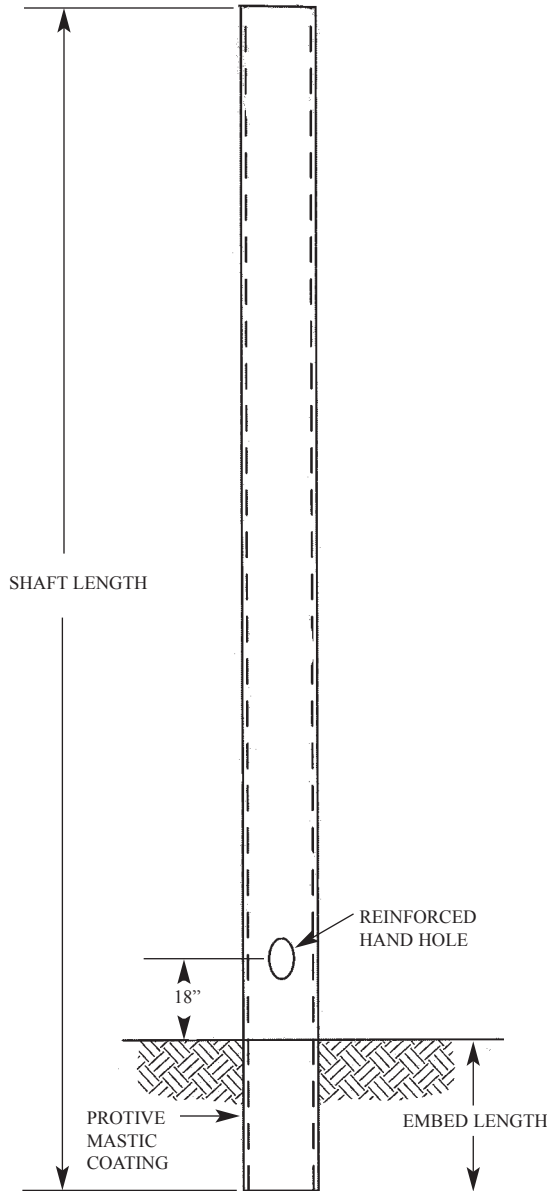

BEARING PLATE

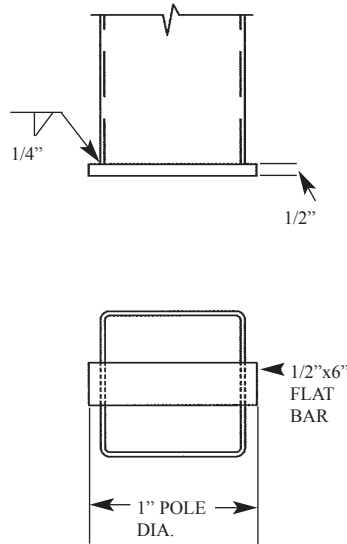

EMBEDDED DATA

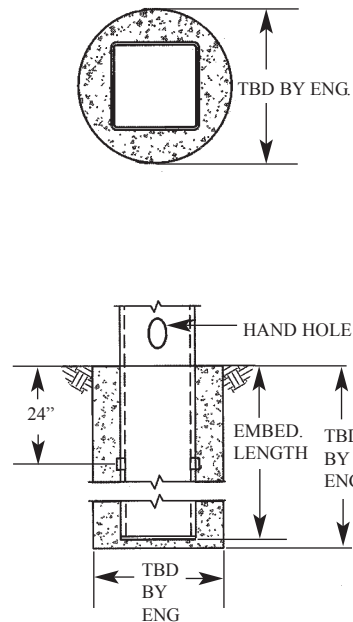

STRUCTURAL DESIGN

Steel poles are designed for the combined effects of both wind and dead load. The wind load effects have been analyzed with wind velocities ranging from 70 to 120 mph plus a 1.3 gust factor. Due to varying wind effects, height correction factors and drag coefficients have been applied to the entire structure. The dead load effects have been determined by using a final deflected position analysis to account for secondary moments caused by eccentric dead loads.

MATERIALS

All Steel pole shafts are made from a single ply steel sheet. This sheet is formed into a tubular shape with one or more longitudinal welds, no weld splices are permitted. This tubular shape has a cross section which is either round or square and is either tapered or non tapered along its length. Standard taper rates include 0.11 inches per foot for square poles and 0.14 inches per foot for round poles. Materials used for the pole shafts meets the requirements of ASTM A500 Grade-C, ASTM A595 Grade A, or ASTM A-572 GR. 65. Poles which exceed 50 feet in length, are designed as two-piece assemblies. These two-piece assemblies are joined together telescoping the upper female section over the lower male section by a minimum lap distance of 1.5 times the female inside diameter. The longitudinally weld seam on the female section is welded both inside and out to insure 100% weld penetration at the telescoped area. Pole assemblies, which exceed 50 feet in height, are also designed with an internal cable guide and strain relief mechanism, which is typically attached at the mid-height of the pole assembly.

EMBEDDED

Embedded poles will be set directly into ground by an embedment distance which is equal to 10% of the free pole height plus 2 feet within a minimum embedment depth of not less than 5'-0". The embedded pole will not utilize a stub base or base plates as an anchoring means, but will rest upon a bearing plate which is integrally welded to the bottom of the pole shaft. The embedded portion of the pole plus 6" will be additionally protected with a masticcoating. The 3"x5" hand holes located 24" below grade and oriented at 180 degrees apart will provide for wire access.

ORDERING LOGIC

Square Non-Tapered (Embedded)							
Catalog Number	Gross Weight (Lbs)	STRUCTURE DATA					
		Pole Shaft Data					
		Section	Base Width (in)	Top Width (in)	Wall Thick (in)	Shaft Length (ft)	Embed Length (ft)
SL-SNSP-10-40-E2-EM	98	Base	4.0	4.0	.1196	15	5
SL-SNSP-12-40-E2-EM	111	Base	4.0	4.0	.1196	17	5
SL-SNSP-14-40-E2-EM	124	Base	4.0	4.0	.1196	19	5
SL-SNSP-15-40-E2-EM	130	Base	4.0	4.0	.1196	20	5
SL-SNSP-16-40-E2-EM	137	Base	4.0	4.0	.1196	21	5
SL-SNSP-18-40-E2-EM	150	Base	4.0	4.0	.1196	23	5
SL-SNSP-20-40-E2-EM	163	Base	4.0	4.0	.1196	25	5
SL-SNSP-20-40-V2-EM	251	Base	4.0	4.0	.1875	25	5
SL-SNSP-20-50-E2-EM	205	Base	5.0	5.0	.1196	25	5
SL-SNSP-20-50-V2-EM	316	Base	5.0	5.0	.1875	25	5
SL-SNSP-25-40-E2-EM	195	Base	4.0	4.0	.1196	30	5
SL-SNSP-25-40-V2-EM	301	Base	4.0	4.0	.1875	30	5
SL-SNSP-25-50-E2-EM	246	Base	5.0	5.0	.1196	30	5
SL-SNSP-25-50-V2-EM	380	Base	5.0	5.0	.1875	30	5
SL-SNSP-30-40-V2-EM	351	Base	4.0	4.0	.1875	35	5
SL-SNSP-30-50-E2-EM	286	Base	5.0	5.0	.1196	35	5
SL-SNSP-30-50-V2-EM	443	Base	5.0	5.0	.1875	35	5
SL-SNSP-30-60-V2-EM	535	Base	6.0	6.0	.1875	35	5
SL-SNSP-30-70-H2-EM	828	Base	7.0	7.0	.2500	35	5
SL-SNSP-30-80-H2-EM	951	Base	8.0	8.0	.2500	35	5
SL-SNSP-35-50-V2-EM	519	Base	5.0	5.0	.1875	41	6
SL-SNSP-35-60-V2-EM	627	Base	6.0	6.0	.1875	41	6
SL-SNSP-35-70-V2-EM	734	Base	7.0	7.0	.1875	41	6
SL-SNSP-35-70-H2-EM	970	Base	7.0	7.0	.2500	41	6
SL-SNSP-35-80-H2-EM	1114	Base	8.0	8.0	.2500	41	6

SEQUOIA LIGHTING
CORPORATION

MANUFACTURERS OF QUALITY LIGHTING PRODUCTS