

POLE TOP INSULATOR PIN ASSEMBLY MOD. #10

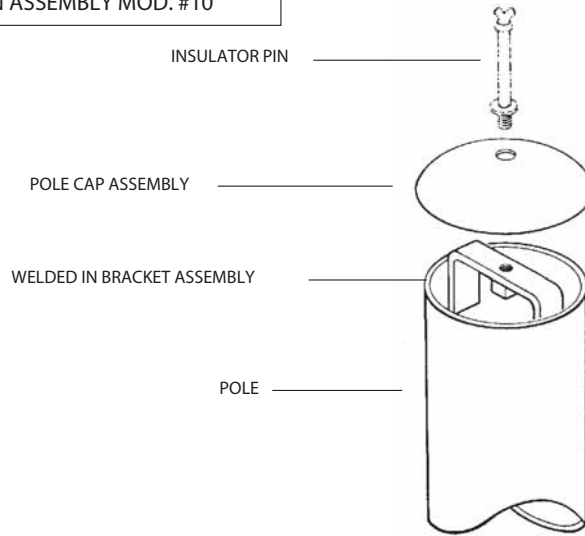

ANGLE STABILIZING ASSEMBLY MOD. #15

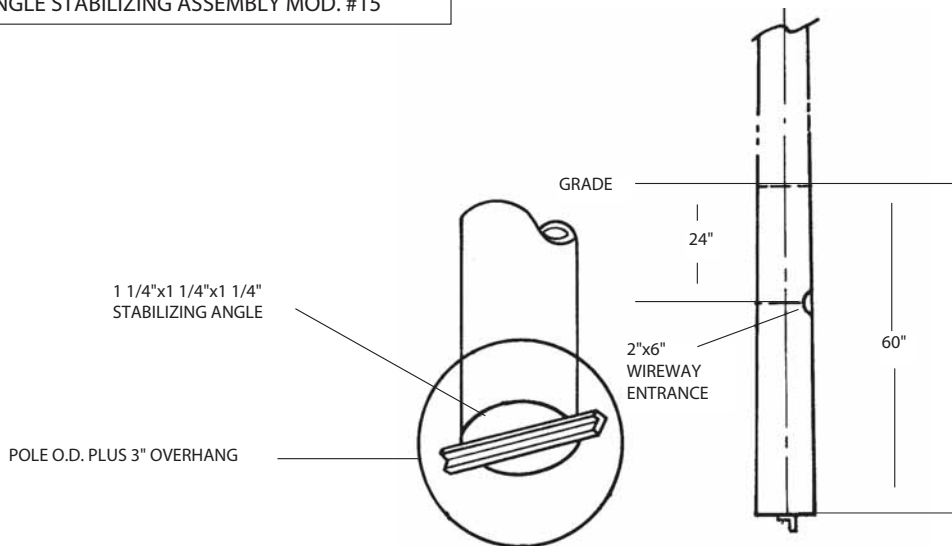

All Sequoia Lighting stabilizing angle assemblies are fabricated from heavy duty thick angle steel and welded to pole bottom for maximum strength. Pole top insulator line assemblies are provided at top of pole to accommodate triplex wiring applications. All units are hot dip galvanized after fabrication.

All modification assemblies are cleaned, etched and primed prior to painting. Standard colors are black, bronze or sequoia powder coated or wet sprayed to match pole. Custom colors and special finishes along with hot dip galvanizing are also available.