

# TYPE 9A PULLBOX

Meeting the department of transportation requirement, the Type 9A Pullbox is designed for use in all types of concrete barriers. Typically used in the harshest of roadway environments, the Type 9A Pullbox provides maximum protection against moisture. The lid is fully gasketed with a neoprene gasket and securely attached with four stainless steel bolts. Each Type 9A Pullbox is manufactured from heavy gauge steel which is hot dip galvanized after fabrication to assure a long, trouble-free life. Every Type 9A Pullbox is provided with 1½" and 2" knock-outs on each side for easy conduit access.

CATALOG #	SERIES	COVER MARKING
9A-SLC	#9A	STREET LIGHTING CALTRANS
9A-SL	#9A	STREET LIGHTING
9A-CC	#9A	COMMUNICATION CALTRANS
9A-C	#9A	COMMUNICATION
9A-TSC	#9A	TRAFFIC SIGNAL CALTRANS
9A-TS	#9A	TRAFFIC SIGNAL
9A-SC	#9A	SOFFIT CALTRANS
9A-S	#9A	SOFFIT
9A-RMC	#9A	RAMP METER CALTRANS
9A-RM	#9A	RAMP METER
9A-CNC	#9A	CONNECTOR CALTRANS
9A-TC	#9A	TELEPHONE CALTRANS
9A-T	#9A	TELEPHONE
9A-GSK	#9A	NEOPREME GASKET

\*1992 SPECIFICATIONS SHOWN, 1988 SPECIFICATIONS AVAILABLE



TYPE 9A PULLBOX

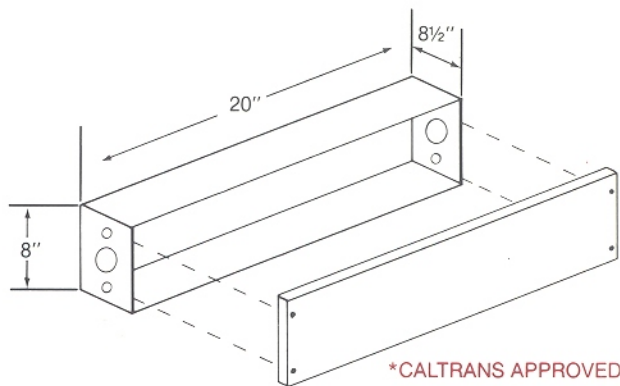

\*CALTRANS APPROVED